

Technical Information

No. FO 5215

Edition: 02/04 - subject to change

Substitutes: Edition --/--

Status: valid

Mercury Short Arc Lamp
for Microlithography

HBO[®] 1500 W/PIL HP

■ Product description

The OSRAM HBO[®] 1500 W/PIL HP is a direct current mercury short arc i-line lamp designed for the manufacture of integrated circuits (microlithography). This lamp type emits a very high radiant intensity in the ultraviolet and visible wavelength range and is especially suited for use in ASML equipment (PAS 5500/22, /100, /100B, /TFH 100). The HBO[®] 1500 W/PIL HP designed for a low intensity degradation over lifetime..

■ Technical data

Order reference	HBO [®]	1500 W/PIL HP
Rated lamp wattage	W	1,500
Rated lamp voltage	V	23
Rated lamp current (=)	A	65
Ignition voltage (cold)	kV _s	max. 20
Radiant intensity (wave length range 365 ± 2,5nm)	mW/sr	4,850
Electrode gap e (cold)	mm	4
Lamp length (overall) l ₁	mm	max. 273
Lamp length l ₂	mm	240 / max. 242
Bulb diameter d	mm	52
LCL a	mm	118
Guaranteed life	h	1,500

Base

- Cathode: SFc 27-10/35
- Anode: SFc 30-6/25 with cooling fins and cable connection

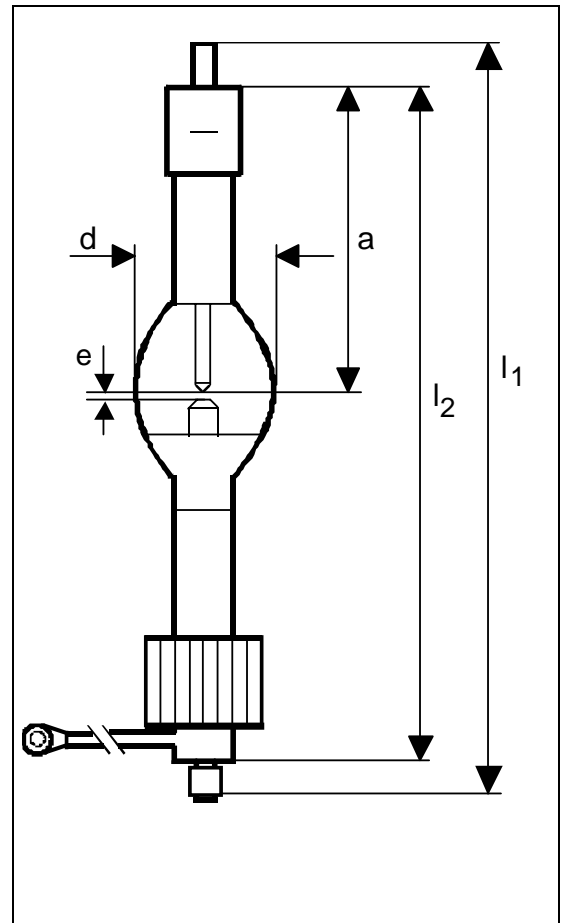

■ Lamp operation

Maximum permissible base temperature	°C	200
Cooling	forced base cooling, cooling fins on anode base	
Burning position	vertical, Anode (+) underneath	

■ Safety Instruction

Because of their high luminous efficacy, the UV radiation which they emit and the high pressure within the lamp, HBO[®] lamps must be operated within enclosed, purpose-built housings. When a lamp breaks, mercury is released. Particular safety regulations must be paid attention (for details please request technical information sheet no. FO 4574).